



Instruction Sheet

Zone Sentry Zone Valve

102-410

SUPERSEDES: January 15, 2011

EFFECTIVE: November 1, 2011

Plant ID# 001-3944

Application:

Taco Zone Sentry Zone Valves provide on-off, normally open or normally closed control in both open and closed hydronic systems. The Taco Zone Sentry valves can be used in a wide variety of applications, specifically designed for use in heating systems and in chilled water systems where condensation is present. It is primarily used in baseboard, fan coils, radiators, convectors, air handlers, heat pumps and radiant applications. Refer to the Product Specifications section for choosing the correct valve model for your application.

Ease of Installation / Operation:

The Zone Sentry is the most technologically advanced zone valve ever made. It's also simple to install and operate. The valve can be installed in any direction, in any orientation except for chilled water installations (see Figure B). We then went a step further, allowing the actuator to be mounted to the valve body in either direction (see Figure A), great for those tight baseboard jobs. Snap-in quick connects on the back of the valve make for a simple, secure and fast wiring hook-up. A green LED light shows full functionality of the valve's operation and thermostat status. Under a no power situation the manual override button located on the top of the valve allows the ball to be rotated up to 90° and is also marked with a slot to indicate the position of the valve.

Figure A

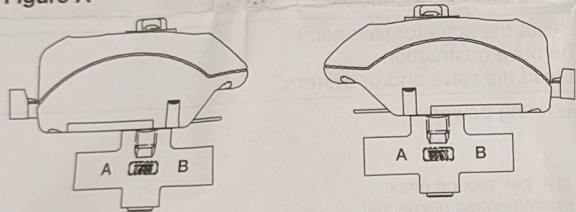

Two Position Head Placement.
Universal Body Placement.
May be installed in any position, any orientation.

Valve Installation:

1. On hot water applications, the valve body may be installed in any orientation. On chilled water installations, do not install with the actuator beyond 85° from the topmost installation (see Figure B).

Figure B

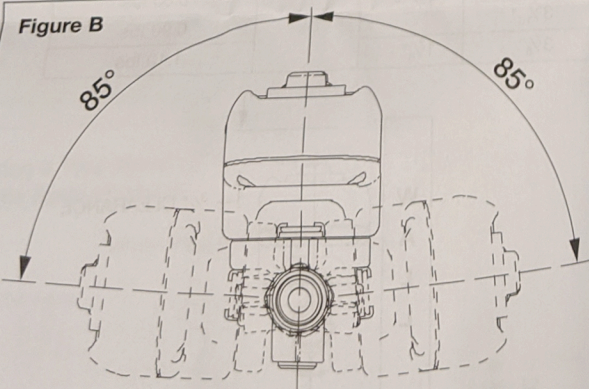

Permitted Angle of Installation on Chilled Water Applications

2. Before mounting the body, refer to Figure C for any clearance requirements.

Figure C

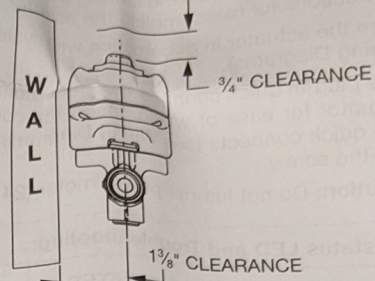

CAUTION: Actuator must be removed from the valve body before soldering (see Figure D). Ball valve must be in the full open position before soldering. Valve shipped in the closed position.

3. Use of a solder with a melting point below 600°F is recommended. Do not overheat! Make sure the ball valve is in the FULL OPEN position during soldering. Direct flame tip away from the center of the valve. Cool valve quickly with a wet cloth.
4. Solder build-up on the ball valve may prevent proper opening and closing of the valve. Actuate the actuator once or twice and make sure the valve rotates fully.
5. Valve body can be submerged for leak testing before the actuator is attached.

Actuator Installation / Wiring:

NOTE: Some power robbing thermostats require the use of a resistor (always use the resistor provided by the thermostat manufacturer with the Zone Sentry). Consult the thermostat instructions for the resistor installation.

1. Actuator Removal: Remove the valve actuator prior to soldering by pushing in and holding the release clip at the front of the actuator and lifting upward approximately 3/4" (see Figure D).
2. To re-assemble the actuator to the valve body: Position actuator such that the "D" shaped valve stem aligns properly with the "D" shaped actuator drive cavity. (Note: The "D" shaped stem design allows for correct insertion every time.) Next, slide the valve stem into the actuator cavity, push in and hold the release

Figure D: Actuator Removal

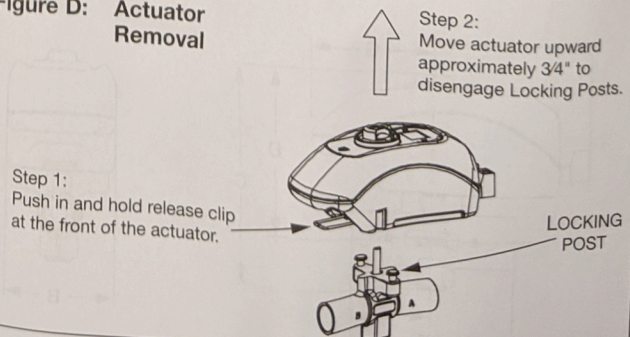

clip until the actuator slips over the valve locking posts (see Figure D). Once the actuator is flush to the valve body, let go of the release clip. Using very little force, try to take the actuator off of the valve body without using the release clip. Both locking posts should be firmly attached to the actuator. If the actuator slides up the stem, repeat the assembly process.

3. Changing the actuator orientation: The actuator may be attached to the valve body in either direction (see Figure A). In order to reverse the actuator orientation on the valve body, see the actuator removal instructions in Step 1 with the following exceptions. Instead of moving the actuator the full $\frac{3}{4}$ ", move it just high enough to clear the locking posts, rotate the actuator 180° and reinstall it on the locking post by following the previous instructions for reassembling the actuator.
4. Wire the actuator in accordance with system requirements (see Wiring Diagrams).
5. The plug-in quick connects can be disconnected from the valve actuator for ease of wiring. Insert the corresponding wire into the quick connects (see Wiring Diagrams) and tighten by turning the screw.
6. **Caution:** Do not jumper power/motor (24 VAC) connection terminals, even temporarily. This may cause damage to the thermostat's heat anticipator.

Mode of Operation:

1. Upon initial field installation the capacitor requires a full charge, up to 35 seconds, before the valve starts to turn. Charging time will vary (typically less) during normal operation.
2. When the capacitor is charging the green LED light will FLASH.
3. Once the capacitor is charged, the green LED will stop flashing but remain ON. At this point the valve's actuator will rotate the ball valve. The green LED will remain ON as long as the thermostat is calling (the unit is powered).
4. Once the thermostat is satisfied the green LED will turn OFF and the valve will rotate 90° into its normal position or non-powered position. For example: If the actuator is an NC (normally closed) version, the actuator would open the valve when the thermostat calls. Once the thermostat is satisfied the actuator would then rotate the valve 90° to its normally closed position.

WARNING: Do not use zone valves on indirect water heaters without a tempering device.

Multi-status LED and Troubleshooting:

LED STATUS	INDICATES	POSSIBLE CAUSE	POSSIBLE SOLUTION
Not Illuminated	Power off	No call No Power	Verify there is a call. Check for voltage at the actuator.
Steady blink (once per second)	Charging		
Solid	Power on		
Slow blink (once every 5 seconds)	Excessive charging time	Not enough VA Too many valves per transformer	Reset the actuator (see note). Use a larger VA transformer or add an additional transformer. Reduce the number of valves. Use a different thermostat.
Double blink (twice every 5 seconds)	Excessive opening time	Obstruction in valve Buildup of contamination in valve	Reset the actuator (see note). Remove obstruction. Clean the valve and/or system.

NOTE: Reset the actuator by removing power for 5 seconds and then restoring power.

Flow Coefficients and Maximum Close-Off Pressure:

VALVE SIZE	C _v (Kv)/Ft. of PIPE EQUIV.*	CLOSE-OFF PSI (kPa)
$\frac{1}{2}$ "	4.9 (4.3) / 9.5	0-125 psi (0-862 kPa)
$\frac{3}{4}$ "	10.3 (8.9) / 8.4	
1"	8.9 (7.7) / 47.4	

* At 4' per second (max. recommended residential flow rate).

Dimensions (for reference purposes):

VALVE SIZE	A	B	C	D	E (Sweat)	E (Threaded)	F	G	WEIGHT (Valve + Actuator)
$\frac{1}{2}$ "	3"	$2\frac{3}{8}$ "	$4\frac{1}{8}$ "	$2\frac{1}{16}$ "	$3\frac{1}{8}$ "	$3\frac{3}{4}$ "	$1\frac{9}{16}$ "	$2\frac{5}{16}$ "	0.85 lbs
$\frac{3}{4}$ "				$2\frac{1}{8}$ "	$3\frac{5}{16}$ "	$1\frac{7}{8}$ "	0.90 lbs		
1"				$3\frac{7}{8}$ "	$3\frac{7}{8}$ "	$1\frac{7}{8}$ "	1.10 lbs		

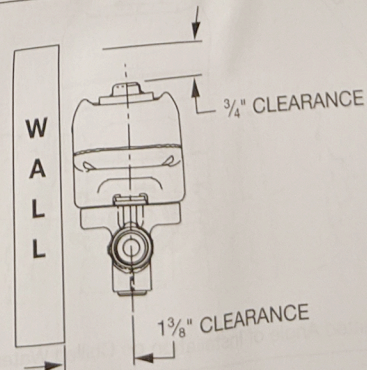
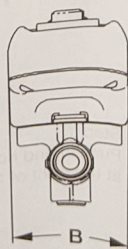
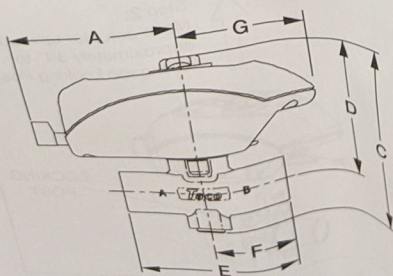

Zone Sentry Zone Valve Wiring Diagrams

WARNING: Wiring connections must be made in accordance with all applicable electrical codes.

CAUTION: To prevent electrical shock, disconnect electric power to system at main fuse or circuit breaker box until installation is complete. When a service switch is installed, more than one disconnect switch may be required to deenergize this device for servicing.

Simplified Internal Schematic:

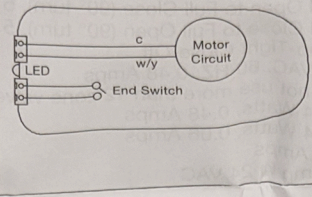

Typical Zone Sentry Zone Valve Wiring:

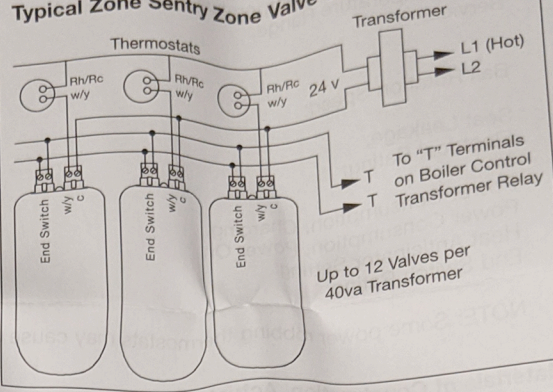

NOTE: Some power robbing thermostats require the use of a resistor (always use the resistor provided by the thermostat manufacturer with the Zone Sentry). Consult the thermostat instructions for the resistor installation.

Wiring a Taco Zone Sentry Zone Valve to Replace a Honeywell, Erie or Sparco Valve:

Honeywell, Erie and Sparco Wire Leads

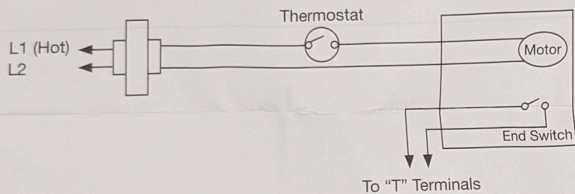

Honeywell and Erie Terminal Block

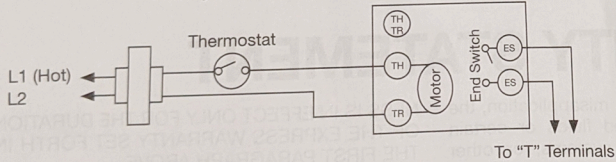

Taco Zone Sentry Zone Valve

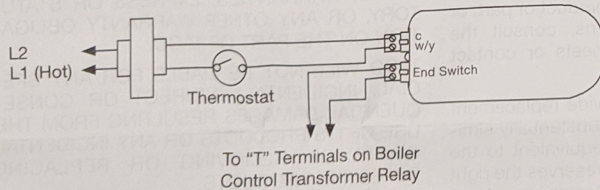

Wiring a Taco Zone Sentry Zone Valve to Replace a Flair or Taco 3-Wire Valve:

Flair

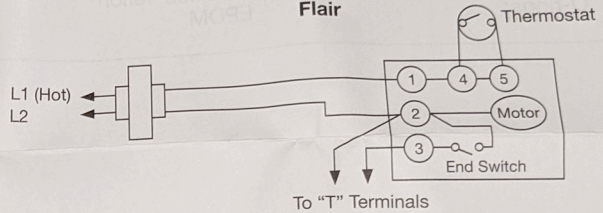

Taco 570 Series

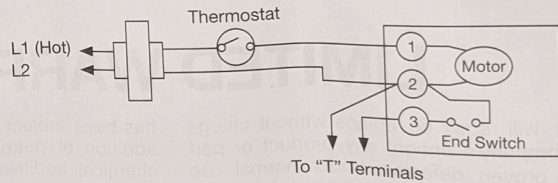

Taco Zone Sentry Zone Valve

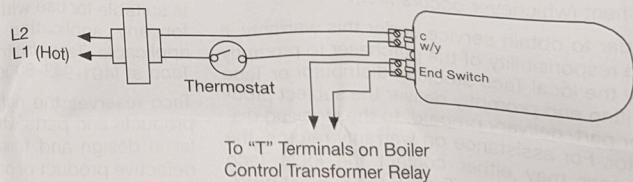

Wiring a Taco Zone Sentry Zone Valve to Replace a White Rodgers Valve:

White-Rodgers (1311 or 1321)

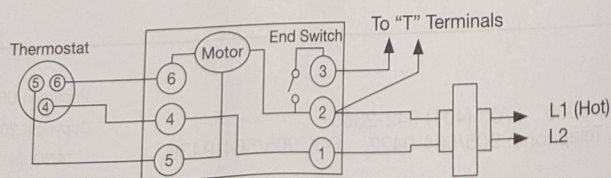

Taco Zone Sentry Zone Valve

